

30 August 1982

**OUTBOARD MOTOR, GASOLINE POWERED,
OMC MODEL AM-40A, NSN 2805-01-089-0989**

Intervals (on-condition or herd time) and the related man-hour times are based on normal operation. The man-hour time specified is the time you need to do all the services prescribed for a particular interval. On-condition (OC) oil sample intervals shall be applied unless changed by the Army Oil Analysis Program (AOAP) laboratory. Change the hard time interval if your lubricants are contaminated or if you are operating the equipment under adverse operating conditions, including longer-than-usual operating hours. The hard time interval may be extended during periods of low activity. If extended, adequate preservation precautions must be taken. Hard time intervals will be applied in the event AOAP laboratory support is not available.

Clean parts with dry cleaning solvent (SD), type II or equivalent. Dry before lubricating. The lowest level of maintenance authorized to lubricate a point is indicated by one of the following: (C) Operator/crew; or (O) Organizational Maintenance.

You can help improve this publication. If you find any mistake or if you know of a way to improve the procedures, please let us know. Your letter or DA Form 2028 Recommended Changes to Publications and Blank Forms) should be mailed directly to' Commander, U.S. Army Troop Support & Aviation Material Readiness Command, ATTN: DRSTS-MPSD, 4300 Goodfellow Blvd., St. Louis, MO 63120. A reply will be furnished to you.

'The time specified is the time required to perform all services at the particular interval.

*TOTAL TASK-H R		*TOTAL TASK-H R	
INTERVAL	TASK-HR	INTERVAL	TASK-HR
M	2.0	20	
Q	1.5	B	1.5 biannually

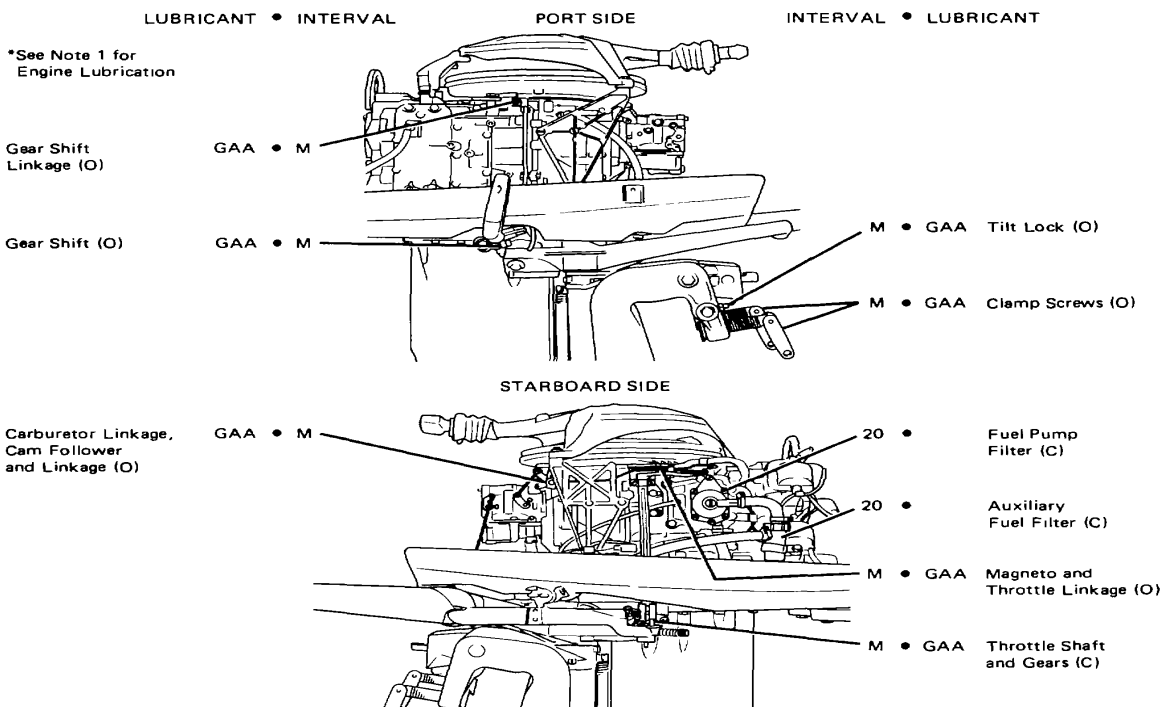

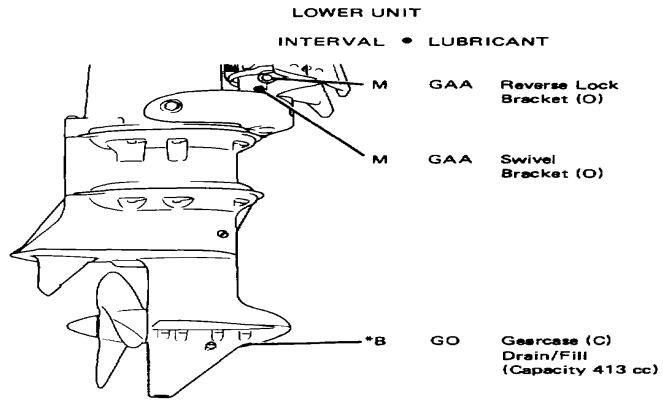
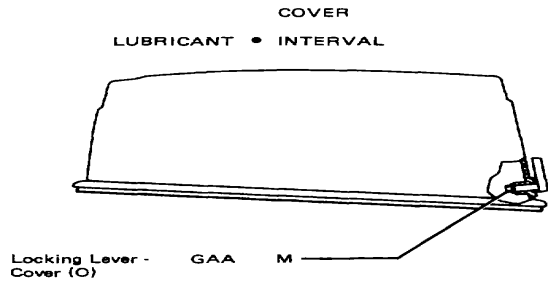

NOTES

***1. FUEL MIXTURE (C)**

1 part approved lubricant to 50 parts gasoline.
8 fl. ozs. lubricant to 3 (three) gallons of gasoline.
16 fl. ozs. lubricant to 6 (six) gallons of gasoline.
20 milliliters lubricant to 1 liter gasoline.

CAUTION

Lubricant and gasoline must be properly mixed or serious damage will result to the engine.

CAUTION

Avoid the use of the following, they will contribute to deterioration of your engine and shorten spark plug life:

AVOID USE OF:

***2 GEARCASE (O)**

Change after first 20 hours of operation and check after 50 hours of operation. Add lubricant if necessary.

Drain and refill every 100 hours of operation or every 6 months, whichever occurs first.

- Automotive oils
- Premix fuel of unknown oil quality
- Premix fuel richer than 50/1 ratio
- Premix fuel leaner than 50/1 mixture ratio

- KEY -

LUBRICANTS		REFILL CAPACITY (APP)	EXPECTED TEMPERATURES			For Arctic Operation Refer to TM 9-207	INTERVALS
			Above +32°F Above 0°C	+40°F to -10°F +5°C to -23°C	0°F to -65°F -18°C to -50°C		
B/A Grade TCW 50/1 NSN 9150-117-8791	Lubricating Oil, Engine	6 gals. (Gas Tank)	TCW 50/1 GO	TCW 50/1 GO	TCW 50/1 GO	M = Monthly B = Biannually 20 = Hours	
GO MIL-L-2015	Gearcase	413 cc					
GAA	Grease	O/C	GAA	GAA	GAA		
MIL-G-2104GR30 (Oil Can Points)	General Purpose Oil						

DISTRIBUTION:
To be distributed in accordance with DA Form 12-25D, Operator maintenance requirements for Outboard Motors.

Copy of this Lubrication Order will remain with the equipment at all times; instructions contained herein are mandatory.

BY ORDER OF THE SECRETARY OF THE ARMY:

E.C. MEYER
General, United States Army
Chief of Staff

OFFICIAL:
ROBERT M. JOYCE
Brigadier General, United States Army
The Adjutant General

RECOMMENDED CHANGES TO EQUIPMENT TECHNICAL PUBLICATIONS



THEN... JOT DOWN THE DOPE ABOUT IT ON THIS FORM, CAREFULLY TEAR IT OUT, FOLD IT AND DROP IT IN THE MAIL!

SOMETHING WRONG WITH THIS PUBLICATION?

FROM: (PRINT YOUR UNIT'S COMPLETE ADDRESS)

DATE SENT

PUBLICATION NUMBER

PUBLICATION DATE

PUBLICATION TITLE

BE EXACT... PIN-POINT WHERE IT IS

IN THIS SPACE TELL WHAT IS WRONG AND WHAT SHOULD BE DONE ABOUT IT:

PAGE NO.	PARA-GRAPH	FIGURE NO.	TABLE NO.
----------	------------	------------	-----------

TEAR ALONG PERFORATED LINE

PRINTED NAME, GRADE OR TITLE, AND TELEPHONE NUMBER

SIGN HERE:

DA FORM 2028-2 JUL 79

PREVIOUS EDITIONS ARE OBSOLETE.

P.S.—IF YOUR OUTFIT WANTS TO KNOW ABOUT YOUR RECOMMENDATION MAKE A CARBON COPY OF THIS AND GIVE IT TO YOUR HEADQUARTERS.

PIN: 051468-000